

Salinity Meter

Pen Style Water Quality Meter

Model EC170

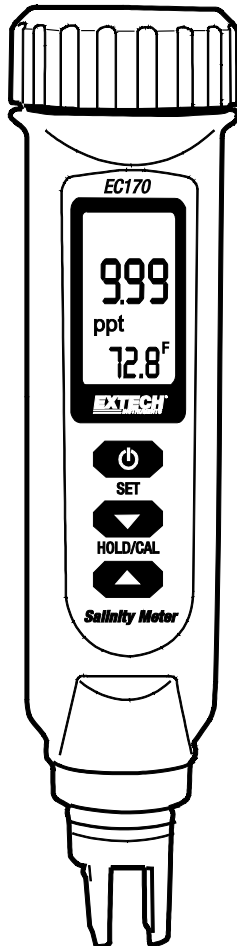

Introduction

Congratulations on your purchase of the Extech Pen Style Water Quality instrument; the Model EC170 measures salinity and temperature. The instrument is housed in an IP65 Water-proof enclosure for safety. This meter is shipped fully tested and calibrated and, with proper use, will provide years of reliable service. Please visit our website (www.extech.com) to check for the latest version of this User Manual, Product Updates, and Customer Support.

Features

- IP65 Waterproof housing
- Automatic and manual range
- Dual Display with ATC (automatic temperature control)
- Data hold for freezing displayed readings
- Low battery indicator
- Automatic power-off for maximum battery efficiency
- Switchable temperature units of measure (°C/°F)
- Multi-point and one-touch calibration features
- Pocket sized, powered by four (4) LR44 batteries

Supplied Materials

- EC170 meter
- Four (4) LR44 button batteries
- Operation instructions

Battery Installation

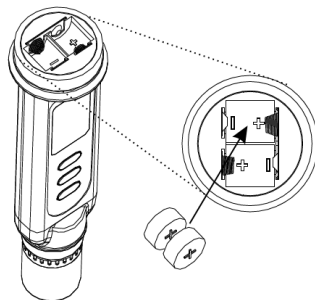

The meter is shipped with the four (4) LR44 button batteries removed. The user must install the batteries before the meter can be used. Refer to accompanying diagram.

1. Unscrew the battery compartment cover (top) in a counterclockwise direction, applying downward pressure. Please do not discard the black washer.
2. Install the four (4) LR44 button batteries, carefully orienting the batteries and observing polarity.
3. Replace the battery compartment cover.
4. Please remove the batteries while the meter is not in use for long periods.



Battery Safety

- Remove and immediately recycle or dispose of used batteries according to local regulations, keeping the batteries away from children. Do NOT dispose of batteries in household trash or incinerate.
- Even used batteries can cause severe injury or death.
- Call a local poison control center for treatment information.
- This unit contains four (4) LR44, 1.5 V, lithium batteries.
- Non-rechargeable batteries are not to be recharged.
- Do not force discharge, recharge, disassemble, heat above 122°F (50°C), or incinerate. Doing so may result in injury due to venting, leakage, or explosion resulting in chemical burns.
- Ensure that the batteries are installed correctly according to correct polarity (+ and -).
- Do not mix old and new batteries, different brands or types of batteries, such as Alkaline, carbon-zinc, or rechargeable batteries.
- Always completely secure the battery compartment. If the battery compartment does not close securely, stop using the product, remove the batteries, keeping the batteries away from children.
- Remove and immediately recycle or dispose of batteries from equipment not used for an extended period of time, according to local regulations.

 WARNING	
<ul style="list-style-type: none">• INGESTION HAZARD : This product contains a button cell or coin battery.• DEATH or serious injury can occur if ingested.• A swallowed button cell or coin battery can cause Internal Chemical Burns in as little as 2 hours.• KEEP new and used batteries OUT OF REACH of CHILDREN.• Seek immediate medical attention if a battery is suspected to be swallowed or inserted inside any part of the body.	

Meter Description

1. Battery Compartment
2. Display
3. Keypad
4. Electrode
5. Electrode protective cap

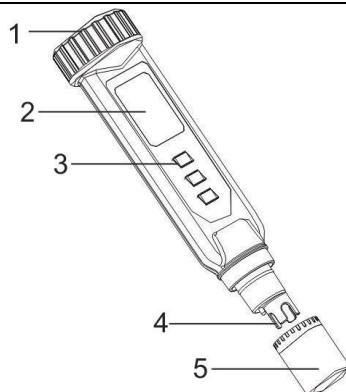

Display Description

1. Data Hold icon
2. Micro- and milli-Siemens units (unused in this meter)
3. Primary measurement reading
4. Parts per thousand salinity units (parts per million ppm are not used in this meter)
5. Temperature reading
6. Temperature units of measure
7. Battery status
8. Calibration icon

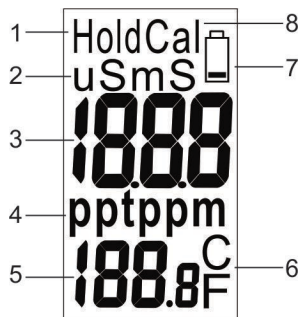

Keypad Description

1. Power ON-OFF and SET button
2. Down Arrow, Data Hold, and Calibration button
3. Up arrow button

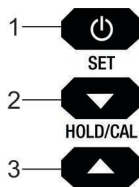

Operation

Getting Started

1. Remove the probe's protective cap (bottom of meter) by pulling the cap firmly downward, away from meter, until it releases (see diagram).
2. Press the power button  to power ON the meter. The meter display will cycle through several icons (representing the current configuration of the meter) before stabilizing.
3. Press the power button to power OFF.
4. This meter is powered by four (4) LR44 button batteries. If the meter will not switch ON, please check that fresh batteries are installed.

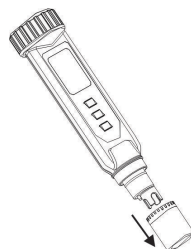

Calibration Required Before Use

The EC170 must be calibrated before use. To calibrate the EC170 a Sodium Chloride (NaCl) reference solution is required. Calibrate the unit per the instructions in the Calibration section.

Automatic and Manual Ranging

There are two ranges: Range 1 (0.00 to 10.00 ppt) and Range 2 (10.1 to 70.0 ppt). The meter defaults to the AUTO Range mode where one of these two ranges is selected automatically. A range can also be selected manually, according to the steps below.

1. Press and hold the  up arrow button, the number 1 (range 1) will appear on the lower right of the LCD and 'ran' (range) will appear at the center of the LCD.
2. Release the button to select range 1.
3. Press and hold the up-arrow button again, the number 2 (range 2) will appear on the lower right of the LCD and 'ran' (range) will appear at the center of the LCD.
4. Release the button to selected range 2.
5. Press and hold the up-arrow button again, 'ATo' will appear on the lower LCD area indicating that the meter is in the AUTO Range mode.
6. Release the button to exit this mode.

Measurement Preparations, Notes, and Considerations

- Accuracy is given as % full-scale; using the lowest range will yield the best accuracy.
- The meter's display will indicate E02 or E03 if the measured value is below (E02) or above (E03) specified range limits. Select another range when an error occurs.
- The temperature coefficient is fixed.
- The normalization (reference) temperature is fixed to 77°F (25°C).
- Rinse the probe with deionized or distilled water before use to remove electrode impurities. When the meter has been idle for a long period, soak the electrode for at least 30 minutes.
- When dipping the probe into a sample solution, eliminate air bubbles trapped in the probe's slot by giving the probe a gentle stir.
- Allow a few seconds for the probe and the sample to reach temperature equilibrium. Ideally, allow 15 minutes to achieve maximum accuracy and best temperature compensation.
- The unit of measure icon will flash while stabilizing. When stable, the icon will stop flashing.
- Press the HOLD button to freeze a displayed reading. Press again to release the display.

Salinity Measurement

1. Calibrate the EC170 as described in the Calibration section (a sodium chloride reference is required). Read the Measurement Preparation section above, before continuing.
2. Insert the electrode into the sample, ensuring that the electrode is completely submerged.
3. Slowly stir the solution with the electrode to remove air bubbles.
4. The meter automatically finds the proper range and then displays the reading at the center of the LCD with the temperature reading shown below, in smaller digits.

Post-Measurement Maintenance

After a measurement session:

- Rinse the electrode in **deionized or distilled** water and store dry.
- Affix the protective cap over the electrode when storing.
- If the unit is left unused for long periods, remove and store the batteries separately.

Automatic Power OFF (Sleep mode)

The meter will automatically switch OFF after 20 minutes of inactivity. To disable the sleep mode: With the instrument switched OFF, long press the SET and HLD/CAL buttons until the 'n' icon appears. Release the buttons and the meter will switch ON. The meter will now remain switched ON until manually switched OFF. Sleep mode is reactivated each time the meter's power is cycled.

Setup Mode

Parameter P1: Temperature Units

1. From the normal operating mode, press the SET button for at least 2 seconds until the '**Px**' icon appears on the bottom of the display (x = setup parameter number).
2. Use the arrow buttons to scroll to the P1.0 icon if necessary.
3. Press the SET button, the '**C**' or '**F**' icon should flash and the '**t.ut**' icon (temperature units) will be visible above the flashing unit.
4. Use the arrow keys to select the unit of measure.
5. Press the SET button to confirm the selection.
6. The display returns to the P1.0 screen.
7. Press the up-arrow button to scroll to the next parameter P3.0 with '**rSt**' displayed (factory default reset) and follow the steps in the next section.

Parameter P3: Factory Default Reset

Use this parameter to restore all settings to the factory default state.

1. If continuing from Parameter P1 skip directly to step 2. If starting from the normal operating mode, long press the SET button for at least 2 seconds until the '**Px**' icon appears (x = setup parameter number) and then use the arrow buttons to scroll to the P3 icon. The '**rSt**' display icon will be visible above the P3 icon.
2. On the P3.0 '**rSt**' screen, press the SET button; a '**y**' or an '**n**' will flash.
3. Use the arrow buttons to select '**y**' for YES RESET or '**n**' for NO RESET.
4. Press the SET button to confirm the setting.
5. Long press the SET button for at least 2 seconds to return to the normal operation mode or press the up-arrow button to move to Parameter P4 (see below).

Parameter P4: Calibration Review for Range 1 and Range 2 Concentrations

1. If continuing from Parameter P3 skip directly to step 2. If starting from the normal operating mode, long press the SET button for at least 2 seconds until the '**Px**' icon appears (x = setup parameter number) and then continue with step 2, below.
2. Use the arrow buttons to scroll to the P4.0 icon if necessary. The '**CAL**' display icon will appear above the P4.0 icon.
3. Press the SET button to view the current Range 1 Calibration Concentration. The P4.0 icon will change to P4.1. If dashes (- -) appear, the meter has not yet been calibrated.
4. Press the up-arrow button to move to the P4.2 display. The displayed value represents the Range 2 Calibration Concentration. If dashes appear, the meter has not yet been calibrated.
5. Long press the SET button for at least 2 seconds to return to the P4.0 '**CAL**' screen.
6. Use the arrow buttons to select another parameter or long press the SET button for at least 2 seconds to return to the normal operation mode.

Calibration

Calibration Preparation and Considerations

The user must first determine:

1. The best calibration schedule for the application.
2. Which sodium chloride calibration standard to use. Read the 'Selecting a Calibration Standard' section below.

Calibration Schedule

- Calibration is necessary and should be performed regularly.
- If measuring in the mid-ranges, calibrate the meter at least once per month and soak the probe in **deionized or distilled water** for 15 minutes before each use.
- If measuring in extreme temperature environments, or at the low end of the measurement range, calibrate the meter at least once per week.

Selecting a Calibration Standard

For best results select a calibration standard closest to the expected sample value. Alternatively, use a calibration solution that is approximately 2/3 the expected full scale measurement range. Do not re-use calibration solutions; contaminants in the solution will affect the calibration and the accuracy.

Salinity Calibration Procedure

1. Insert the probe in **deionized or distilled water** for approximately 30 minutes to rinse.
2. Select the Sodium Chloride standard that is closest to the expected measurement range.
3. Fill two clean sample cups with the solution to a depth of at least 1.2 in. (3 cm).
4. Switch the meter ON.
5. Rinse the probe in one of the solutions, gently stirring the probe, to remove contaminants that might cause measurement errors.
6. Dip the rinsed probe into the other sample. Tap or move the electrode in the sample to dislodge air bubbles. Let the probe stabilize to the solution temperature.
7. Long press the **HOLD/CAL** button (approximately 2 seconds) until the salinity value and the '**CAL**' icon begin flashing on the LCD.
8. Use the arrow buttons to adjust the displayed value so that it matches the value of the standard solution. The reading can be adjusted $\pm 30\%$. If a larger adjustment is needed, the electrode likely needs cleaning.
9. When the **CAL** icon stops flashing, press the SET button to confirm the value. The meter will then return to the normal measurement mode.
10. If the Salinity reading exceeds the $\pm 30\%$ window, the display may freeze. In this case, remove one of the batteries to switch the meter OFF. Do not use the meter again until the electrode has been cleaned or replaced.

Maintenance

- **Keep the electrode clean.** Between measurements, rinse the electrode with **deionized or distilled water**. If the electrode has been exposed to a solvent immiscible in water, clean it with a solvent miscible in water, e.g. Ethanol, and then rinse carefully.
- **Store the electrode carefully.** Before storing, rinse in **deionized or distilled water** and store dry.

Troubleshooting

Power ON is attempted but there is no display

- Press the ON-OFF button for at least 100mS.
- Check that the batteries are positioned correctly, with correct polarity alignment, making good contact.
- Remove and reinstall the existing batteries.
- Replace the batteries.

Display switches OFF

- This is normal when Auto Power OFF is activated.
- Replace the batteries if necessary.

Air Bubbles adhered to Electrode

- Stir the electrode and be sure to dip the electrode into a solution at an oblique angle. Vertical dipping can cause air bubbles.
- Gently tap the bottom of the solution container while stirring the electrode in the solution.
- Air can be blown across the electrode before dipping it into the solution.

Error Codes

- Refer to the Table below for details on Error Codes displayed by the meter.

Code	Description	Suggestions
----	Measurement out of range	In Manual Range mode, long press the up arrow for 2 seconds to change range or use the Auto Range mode
E03	Salinity is out of range	Check against a standard buffer solution. If problems persist, have the meter serviced
E04	Temperature error	Repair meter
TEMPERATURE ERRORS		
E01	Temperature circuit damage	Repair meter
E02	Temperature is below range or circuit damaged	Check again at room temperature. If errors persist, repair meter
E03	Temperature is above range or circuit damaged	Check again at room temperature. If errors persist, repair meter

Factory Default Settings

Type	Parameter	Default	Notes
P1.0	Select °C/°F	°C	Temperature units
P3.0	Revert to factory default settings	NO	Select YES to revert to default
P4.1	Review previous calibration data	-----	Calibration data for Range 1
P4.2		-----	Calibration data for Range 2

Specifications

Measurement ranges	Range 1: 0.00 to 10.00 ppt Salinity Range 2: 10.1 to 70.0 ppt Salinity <i>ppt = parts per thousand</i> 1ppt = 1 g/L
Salinity Accuracy	Range 1: 1% Full Scale ±1digit or 2% Full Scale Range 2: ±1digit
Salinity Resolution	Range 1: 0.01ppt Range 2: 0.1ppt
Temperature Accuracy	±0.9°F (0.5°C)
Temperature Resolution	0.1°
TDS Factor	Built-in NaCl conductivity to TDS conversion factor
Calibration	One point calibration per range
Auto Power OFF	After 20 minutes of inactivity
Data Hold	Freezes displayed reading
Automatic Temperature Compensation (ATC):	32 to 122°F (0 to 50°C)
Waterproof	IP65 rated
Temperature Coefficient	Built-in NaCl temperature coefficient
Operating Conditions	Temperature: 32 to 122°F (0 to 50°C); <80%RH
Storage Conditions	Temperature: 32 to 140°F (0 to 60°C); <90%RH
Normalization Temperature	77°F (25°C), fixed
Status indicators	Out-of-range (----) and low battery
Power Supply	Four (4) LR44 button batteries
Dimensions	Meter: 6.5 x 1.4 x 1.3 in. (165 x 35 x 32 mm) LCD: 1.2 x 0.7 in. (30 x 18 mm)
Weight	4 oz. (115 g)

Two-year Warranty

Teledyne FLIR warrants this Extech brand instrument to be free of defects in parts and workmanship for two years from date of shipment. To view the full warranty text please visit:

<https://www.flir.com/support-center/warranty/instruments/extech-product-warranty/>

Calibration and Repair Services

Teledyne FLIR offers calibration and repair services for the Extech brand products we sell. We offer NIST traceable calibration for most of our products.

Customer Support

Local Telephone Support List: <https://support.flir.com/contact>

Return Material Authorization (RMA): <https://customer.flir.com/Home>

Customer Service: <https://support.flir.com/ContactService>

Technical Support: <https://support.flir.com>

Copyright © 2026 Teledyne FLIR Commercial Systems, Inc.

All rights reserved including the right of reproduction in whole or in part in any form.

www.extech.com

This document does not contain export-controlled information.

