

EXTECH

USER MANUAL

Heavy Duty Hot Wire CFM Thermo-Anemometer

Model 407119

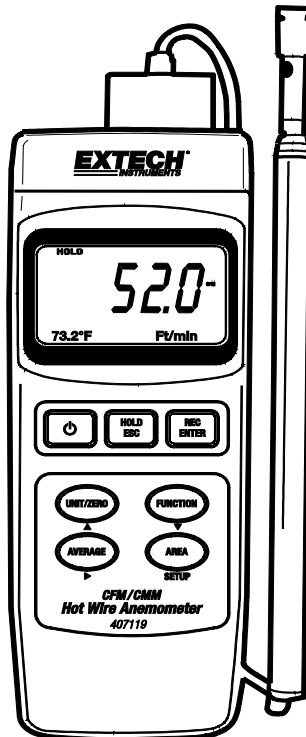

Introduction

Congratulations on your purchase of the Extech 407119 Thermo-Anemometer. The 407119 measures air velocity, air volume, and air temperature. A telescoping probe antenna allows convenient access to grills and diffusers. Careful use of this meter will provide years of reliable service.

Features

- Combination hot wire probe (air velocity) and thermistor sensor (temperature) deliver rapid and precise measurements even at low air velocities.
- Slim probe design with telescoping antenna for easy grill and diffuser access.
- Air Velocity, Air Volume, and Air Temperature measurements.
- 20-reading averaging.
- Zero adjustment.
- Data Hold and MAX/MIN functions.
- Automatic Power OFF (APO).
- PC Interface (RS-232) with optional software and cable for data acquisition.

Applications

Environmental testing, air conveyors, flow hoods, clean rooms, air balancing, fans/motors/blowers, furnace velocity, paint spray booths, and more.

Meter Description

1. Display
2. POWER button
3. HOLD and ESC button
4. REC and ENTER button
5. UNIT, ZERO, and ▲ up arrow button
6. Function and ▼ down arrow button
7. AVG. and ► right arrow button
8. AREA SETUP button
9. Tilt stand
10. Battery compartment
11. Tripod mount
12. Display contrast adjustment
13. System reset switch
14. RS-232 output terminal
15. 9V power adaptor port

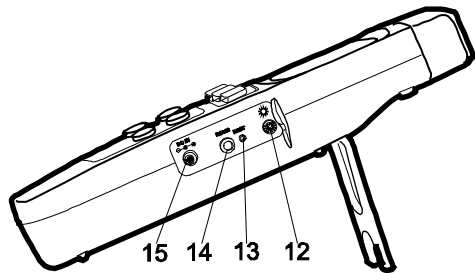
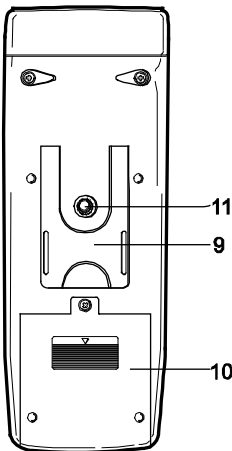
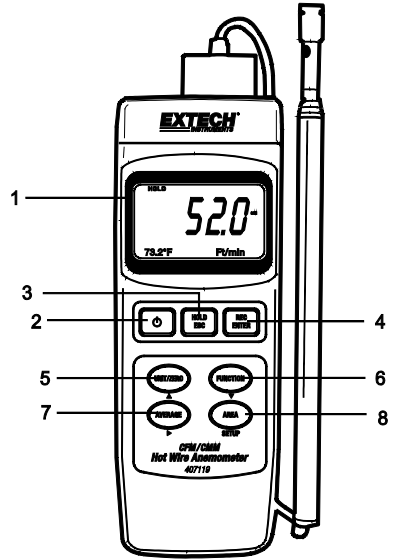

Operation

Initialization and Zero Procedures (please follow these steps before use)

Important: The probe lock must be in the locked position (with the probe inserted) for proper operation. Refer to the accompanying diagram or the diagram at the top of the meter for lock orientation.

For the best accuracy and for proper operation, the following steps must be performed.

1. Connect the sensor to the input jack at the top of the meter by first unlocking the sensor jack and then inserting the sensor plug. Lock the sensor jack after the probe is inserted.
2. Press the POWER button to switch ON the meter. The meter will perform a self-test during which the display will count down from 9999 to 0000.
3. Select the air velocity function using the FUNCTION button. The display will indicate the most recently selected unit of measure for air velocity.
4. To change the temperature unit of measure (C/F), see the advanced programming section of this manual.
5. Short press the UNIT button to change the air velocity units. The display will show the selection.
6. Place the sensor cover in the up (ZERO) position (see diagram below).
7. Extend the telescoping sensing antenna to a convenient length.
8. Place the sensor in the area to be measured and allow time for the sensor to stabilize to the ambient temperature.
9. To zero the display, long press the ZERO button until the second beep is heard.

Warning! Do not touch the air velocity or temperature thermistors inside the sensor head while moving the sensor cover.

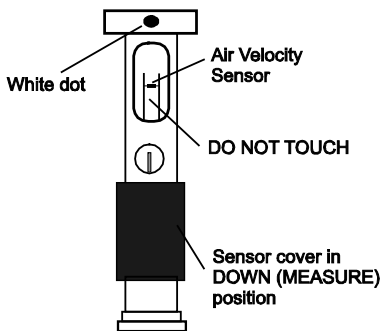
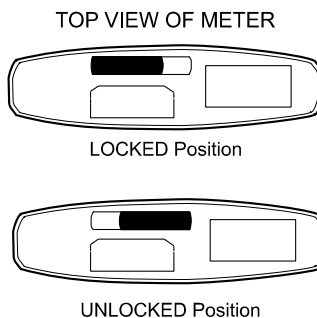

Measurement Position

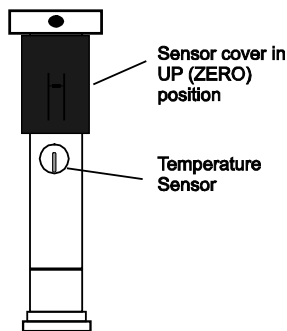

Zero Position

Air Velocity Measurements

1. Follow the initialization and zeroing procedures, above, before continuing.
2. Extend the antenna to the desired length.
3. Slide the air velocity sensor cover downward.
4. Press the POWER button to switch ON the meter.

5. Place the sensor in the air current to be measured. Have the air flow meet the sensor head in the direction of the white dot (as shown in diagram).



6. View the air velocity and temperature readings on the display. The large main display area shows the air velocity reading; the lower display digits show the temperature reading (left) and the unit of measure (right).
7. To switch OFF the meter, long press the POWER button.

Air Flow (Volume) Measurements (CMM / CFM)

NOTE: Temperature is not displayed while the meter is in the air flow mode.

1. Follow the steps in the initialization and zeroing sections, above, before continuing.
2. Select the air flow mode using the Function button. The display will indicate CMM (cubic meters per minute) or CFM (cubic feet per minute) when air flow is selected.
3. Short press the UNIT button to select the desired air flow units (CMM or CFM). The display will indicate the selection.
4. Calculate the area of the duct or vent under test (refer to the Useful Conversions and Equations sections, below). Be sure to compute the area of the vent or duct in square feet or meters. If you noted the area in inches or centimeters, convert to feet or meters before entering the area value.
5. Press the AREA SET button to begin entering the area in m^2 or ft^2 . The left digit will begin flashing. Follow the steps below to enter the area of the duct or vent:
 - Use the ► button to prepare a digit (digit will flash)
 - Use the ▲ button to increase the value of the flashing digit
 - Use the ▼ button to decrease the value of the flashing digit
6. Press the REC/Enter button and then the AREA SET button to save the area.
7. The new area value appears on the lower left of the display in ft^2 or m^2 . If the unit of measure is CFM, the area will be shown in square feet. If the unit of measure is CMM, the area will be shown in square meters.
8. Press the ESC button to abort the programming at any time.

9. Place the probe in the area under test. The main display digits will indicate the air flow in CFM or CMM. If the reading exceeds 99999, use the displayed x10 multiplier to calculate the reading.
10. To switch the meter OFF, long press the POWER button.

AVERAGE Feature for the Air Flow Mode

In the Average mode, up to 20 readings can be stored and averaged.

1. In the air flow mode (discussed earlier), short press the FUNCTION button until the AVG icon and 'zero' icon appears on the lower display area.
2. Press the AVG START button to record the current reading. A '1' will appear in the lower display area indicating that one reading has been stored.
3. Use the AVG START button to average up to 20 measurements. The number in the lower display area will increment with each press of the AVG START button. Note that only the averaged reading is shown while in this mode, not the actual reading.
4. To clear (erase) all the currently stored readings and start again, long press the AVG button until the meter beeps twice. The counter resets to '0' and the meter is ready to start another averaging session.
5. Use the FUNCTION button to exit this mode.

Data Hold Feature

1. While taking measurements, press the HOLD button to freeze a reading.
2. The HOLD indicator will appear on the display.
3. Press HOLD again to return to normal operation.

Maximum (MAX) and Minimum (MIN) Recording

The MAX / MIN feature allows the user to record and view the highest and lowest readings during a measurement session.

1. Press the REC button once. The REC indicator will appear on the display and the meter will begin recording the MAX and MIN values.
2. To view the MAX reading, press REC again. The MAX indicator along with the maximum reading will appear.
3. Press REC again to view the minimum value, the MIN indicator along with the minimum reading will appear.
4. To return to normal operation, long press the REC button until the meter beeps. The display indicators REC, MAX, and MIN will disappear.

Note: Auto Power Off is disabled in the RECORD mode.

Auto Power OFF (APO)

The meter will automatically switch off after approximately 15 minutes of inactivity. To temporarily disable APO, press the REC button to enter the RECORD mode. This will disable APO until the meter's power is cycled. To permanently disable APO, use the Advanced Programming menu.

Advanced Programming Menu

From the air velocity mode, long press the SET button until the meter beeps and a '1' is displayed. The Auto Power OFF and Temperature Units settings are available in this menu. Use the ESC button to exit at any time.

Auto Power OFF (APO) Enable/Disable

Use the up and down arrow keys to select the desired value. '0' disables APO; '1' enables APO. Short press the SET button to move to the next parameter.

Temperature Units selection (C/F)

Use the up and down arrow keys to select the desired value. '0' selects degrees 'C'; '1' selects degrees 'F'. Press the Rec/Enter button to confirm. Press the ESC button to exit.

System Reset

If the display freezes, perform a system reset, using one of the following methods.

1. Move the probe lock switch from ON to OFF and then back to ON, and then switch the meter ON.
2. Press and hold the RESET button (side compartment) using a paper clip or similar tool while switching the meter ON.

RS-232/USB PC Interface

To stream data to a PC, using the meter's RS232 jack, you must obtain the Extech 407001-USB kit (interface cable and PC driver) and the Extech 407001-PRO (software) from the Extech website or an authorized Extech distributor. Install the driver on the PC, connect the meter to the PC, and run the 407001-PRO software to communicate with the meter.

Battery Replacement

When the battery icon appears on the lower left corner of the display, the four (4) 'AA' batteries must be replaced. Please dispose of batteries responsibly.

1. Remove the rear Phillips head screw.
2. Slide off the rear battery compartment.
3. Replace the batteries.
4. Secure the battery compartment.



Never dispose of used batteries or rechargeable batteries in household waste.

As consumers, users are legally required to take used batteries to appropriate collection sites, the retail store where the batteries were purchased, or wherever batteries are sold.

Specifications

Display	Dual function 5-digit LCD
Measurement units	Air Velocity: m/s, km/h, ft/min, knots, mph Air Flow: CMM (m ³ /min) and CFM (ft ³ /min) Temperature: °C and °F
Data hold	Freezes displayed reading
Display update rate	1 update per second (approx.)
Sensors	Air velocity and temperature sensors (thermistor)
MAX/MIN memory	Record and view Maximum and Minimum readings
Average feature	Average up to 20 readings
Automatic power off (APO)	Auto shut off after 15 minutes
Data Output	RS-232 PC serial interface with 16-bit data stream
Operating temperature	0 to 50°C (32 to 122°F)
Operating humidity	80% RH maximum
Power Supply	Four (4) 'AA' 1.5V batteries or optional power adaptor
Power consumption	70 mA DC (approx.)
Weight (meter only)	521 g (1.15 lbs.) with batteries
Dimensions	Meter: 200.0 x 76.2 x 36.8 mm (7.9 x 3.0 x 1.5 in.) Sensor: 12.7 mm (0.5 in.) diameter Min. length of sensor: 260 mm (8 in.) Max. length sensor: 0.94 m (37 in.) Cable length: 1.7 m (5.5 ft.)

Range Specifications

Air Velocity	Range	Resolution	Accuracy (of rdg)
m/s (meters per second)	0.2 to 17.0 m/s	0.1	±(5%rdg + 0.5 m/s)
km/h (kilometers per hour)	0.7 to 61.2 km/h	0.1	±(5%rdg + 1.8 km/h)
ft/min (feet per minute)	40 to 3346 ft/min	1	±(5%rdg + 98 ft/min)
mph (miles per hour)	0.5 to 38.0 mph	0.1	±(5%rdg + 1.1 mph)
knots (nautical miles per hour)	0.4 to 33.0 knots	0.1	±(5%rdg + 1.0 knots)
Air Flow	Range	Resolution	Area Range
CMM (cubic meters per min.)	0 to 36,000 m ³ /min	0.001 to 1	0.001 to 30.0 m ²
CFM (cubic feet per minute)	0 to 1,271,200 ft ³ /min	0.01 to 100	0.01 to 322.91ft ²
Air Temperature	Range	Resolution	Accuracy
	0 to 50°C (32 to 122°F)	0.1°	±0.8°C (1.5°F)

Useful Equations and Conversions

Area equation for rectangular or square ducts

$$\text{Area (A)} = \text{Width (W)} \times \text{Height (H)}$$

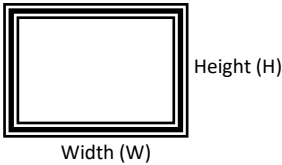

Area equation for circular ducts

$$\text{Area (A)} = \pi \times r^2$$

Where $\pi = 3.14$ and $r^2 = \text{radius} \times \text{radius}$

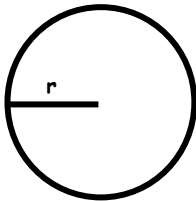

Cubic equations

$$\text{CFM (ft}^3/\text{min)} = \text{Air Velocity (ft/min)} \times \text{Area (ft}^2\text{)}$$

$$\text{CMM (m}^3/\text{min)} = \text{Air Velocity (m/sec)} \times \text{Area (m}^2\text{)} \times 60$$

NOTE: Measurements made in *inches* must be converted to feet or meters before using the above formulae.

Unit of Measure Conversion Table

	m/s	ft/min	knots	km/h	MPH
1 m/s	1	196.87	1.944	3.6	2.24
1 ft/min	0.00508	1	0.00987	0.01829	0.01138
1 knot	0.5144	101.27	1	1.8519	1.1523
1 km/h	0.2778	54.69	0.54	1	0.6222
1 MPH	0.4464	87.89	0.8679	1.6071	1

Three-year Warranty

Teledyne FLIR warrants this Extech brand instrument to be free of defects in parts and workmanship for three years from date of shipment (a six-month limited warranty applies to sensors and cables). To view the full warranty text please visit:

<https://www.flir.com/support-center/warranty/instruments/extech-product-warranty/>.

Calibration and Repair Services

FLIR Systems, Inc. offers calibration and repair services for the Extech brand products we sell. We offer NIST traceable calibration for most of our products.

Contact Customer Support

Local Telephone Support List: <https://support.flir.com/contact>

Return Material Authorization (RMA): <https://customer.flir.com/Home>

Customer Service: <https://support.flir.com/ContactService>

Technical Support: <https://support.flir.com>

Copyright © 2025 Teledyne FLIR Commercial Systems, Inc.

All rights reserved including the right of reproduction in whole or in part in any form

www.extech.com

This document does not contain export-controlled information

